

600 lbs Single Door

ElectroMagnetic Lock with Feedback (WBA0E600EMSFB)

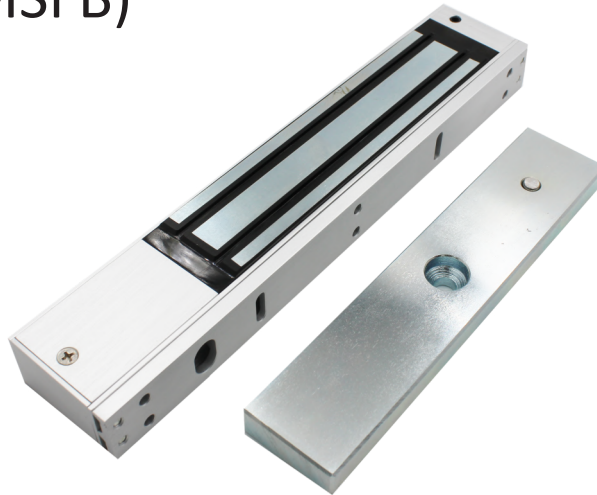

WBOX EM Locks are designed to meet basic access control applications. These locks provide an auxiliary locking mechanism with no moving part for trouble free process. These locks are fail-safe type and suitable for access control applications. Glass door, wooden door, fireproof door, sliding door and metal door can be fixed with single door magnetic lock with holding force of 600 lbs. Material of EM lock is Aluminum. Special anti-residual magnetism design makes the access control automation safer and EM lock more durable

Key feature

- Holding power : Upto 280KGS / 600 lbs
- Operating Voltage : 12VDC
- Operating Current : 270mA
- Safety mode : Power-on to lock, Power-off to unlock
- Weight : 2 kg
- Operating Temperature : -10°C ~ +55°C
- Power : 12-24VDC
- Indication : LED
- Lock Status Monitoring : Yes

PART# : WBA0E600EMSFB

Dimensions : 240x47x27mm

Specifications

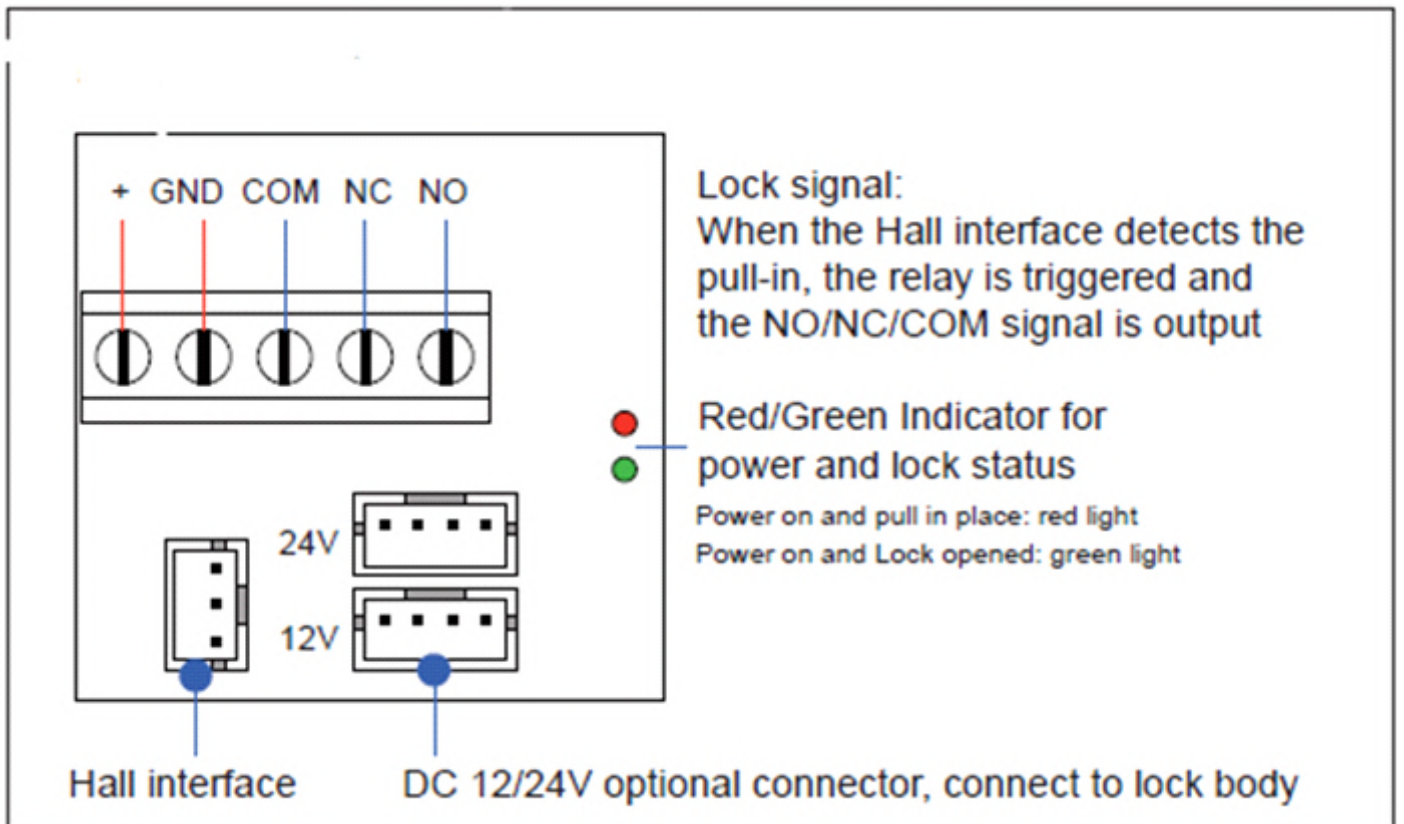
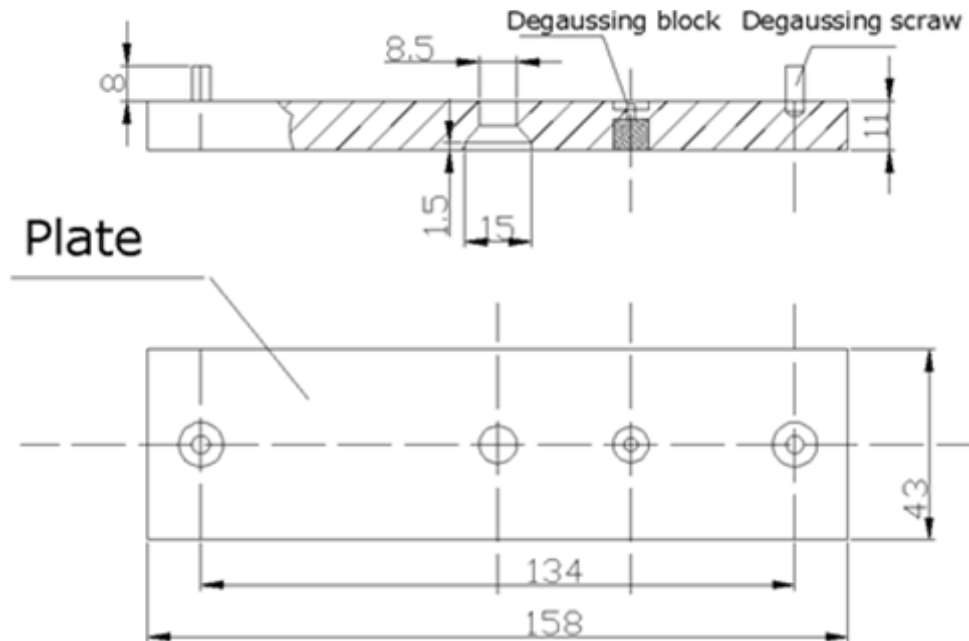

*The product is subjected to continues research and development, the specification might be revised without prior notification kindly refer to the latest spec sheet for updated specification