

NAC-6015UB



U Bracket for 280Kg locks



DESCRIPTION

The NAC-6015UB is a U bracket used to mount electromagnetic locks of 280Kg (630Lbs) for access control door security. It is specially designed and fabricated to hold the weight of the magnetics locks.

APPLICATION

Office areas, schools, communities, office buildings, hotels, shopping malls, shops, public service places, etc.

FEATURES

- Works with 280Kg Magnetic lock
- Downside frameless glass door U bracket

TECHNICAL PARAMETERS	
Model	NAC-6015UB
Material Selection	High Strength Aluminum, Sandblast Finished
Suitable for Door	In-swing Door
Opening Mode	90° Degrees Door
Finished for Shell	Anodized aluminium
Product Dimension	180 x 43 x 28 mm
Product Weight	0.42Kg

NAC-6015UB

U Bracket for 280Kg locks

DIMENSION

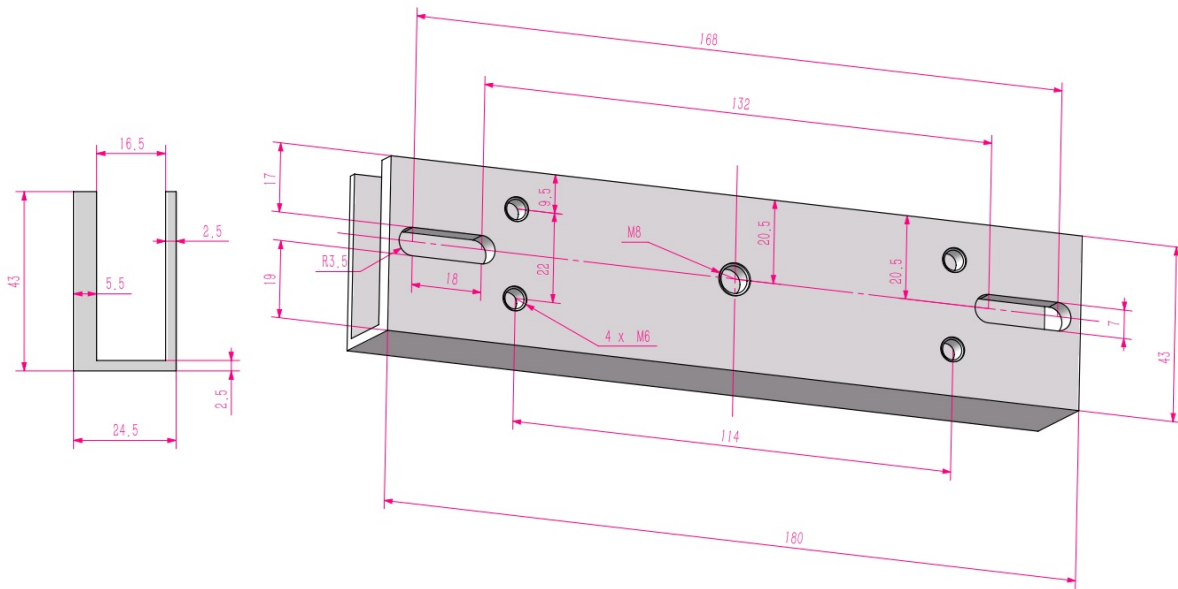

ORDERING INFORMATION

Part Number	Description
NAC-6015UB	U Bracket for 280Kg locks